

BRUCHA®



PANELS
THAT
CONNECT.

Handling
Details



Handling

INFORMATION ON TRANSPORT, STORAGE AND ASSEMBLY

Installation guidelines available at: www.brucha.com/downloads or get in touch with your personal contact person in our company.

GENERAL

For roof and wall cladding, the sandwich element is one of the advanced prefabricated elements. The sandwich element protects against weather influences and acts as thermal insulation and vapor barrier.

The roof and wall cladding is complete after the elements have been laid and fastened, and the edge finishes added (ridge, verge, eaves, base, window and door jambs).

PACKAGING AND TRANSPORT

The panel packs are created in such a way to achieve optimal utilization of the trucks and to be able to guarantee the best possible load securing.

The driver is jointly responsible for loading the truck and ensuring proper transport. The loading and the load securing of the trucks is carried out in accordance with the legal requirements!

DELIVERY

A problem-free driveway with a semi-trailer truck as well as an overlength truck is to be provided or created on site. Please check immediately for completeness and any damage.

Report any complaints immediately upon acceptance:

- by a written note on the transport documents (CMR) with the license plate number and name of the driver, as well as
- photo of the affected goods still on the truck, with packing slip, on which the order number including product description can be seen.

The damage must be clearly visible. Later complaint cannot be accepted.

UNLOADING

When unloading, use either straps together with unloading planks (see detail below) or a suitable sideshift forklift. Please be very careful when unloading forklifts. Crane beams or traverses are to be used for panel lengths of more than 8 m.

Never unload two stacks of panels at the same time!

The unloading staff provided by the recipient is responsible for the undamaged unloading of the goods. Please note the dwell time regulations according to the delivery notification.

up to max. 26.25 ft / 8 m length:

x = max. 9.9 ft / 3 m

y = max. 13.1 ft / 4 m

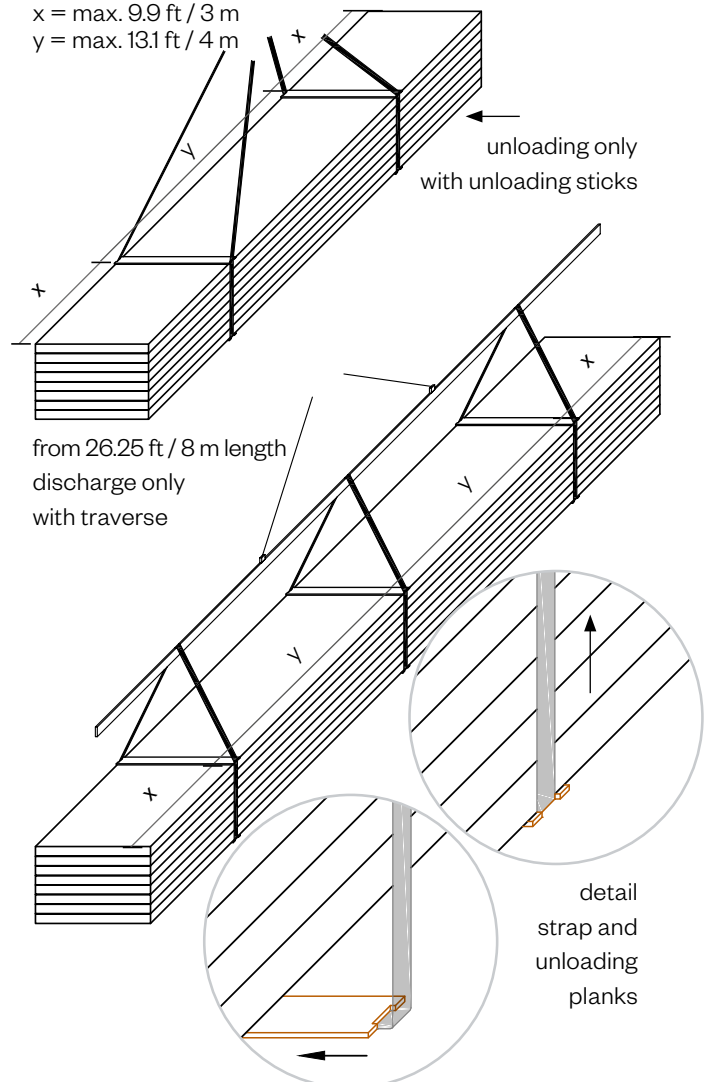



Handling

STORAGE

Stack a maximum of two panel packs on top of each other. Protect these joints from solar radiation and rain by covering them with tarpaulins (ventilated to avoid condensation). Secure opened panel packs. Place the panel packs on a slight incline to avoid backwater (cut open the packaging foil in the lower area).

PROTECTIVE FILM

The PVC protective film is not UV-resistant (protect from direct sunlight). The film must be removed before installation or immediately afterwards.

By default, the BRUCHA panel PIR+ roof – DP is delivered without foil on the interior side.

CUTTING TO SIZE

The use of angle grinders when cutting panels is not permitted. Red-hot metal particles form, which „burn“ into the coated metal surfaces. This creates countless rust spots on the panel surface. Due to the high cutting speed, angle grinders distribute the material to be ground over a very large area.

Use hand-held circular saws with carbide-tipped saw blades or specially suitable chain saws. This type of cold cut ensures the cathodic protective effect of the cut edge.

Immediately remove the cutting chips from the surfaces, as soon as they get wet they will rust and cause the same type of damage as described above.

SUPPORT / SUBSTRUCTURE AND ATTACHMENT

The elements can be mounted or screwed to substructures made of steel or wood using the required sealing tape (see the explanations in the installation guidelines).

Consider the national regulations for fasteners. We generally recommend the use of stainless steel screws, these are mandatory for visible attachment.

ROOF PITCH

The minimum roof pitch must be observed:

- roofs without butt joints and roof penetrations at least 3° (5.2 %)
- roofs with butt joints and roof penetrations at least 5° (8.6 %)

In practice, roof pitches are often referred to as percentages, convertible to angular degrees.

But be careful – this is not the same.

Conversion factor: 1° = 1.73 %

Handling

LIFTING THE PANELS

If panels cannot be mounted manually, suitable slinging gear must be used, compliant with the required safety measures. Ensure that the sheet steel surfaces are protected. It is very difficult to remedy damages. From an economical point of view, mounting of the roof panels using a mounting tool has proven itself (Fig. 1).



Fig. 1
mounting tool

The use of commercially available octopuses (Fig. 2) is recommended for mounting large area panels (roof, wall and facade).

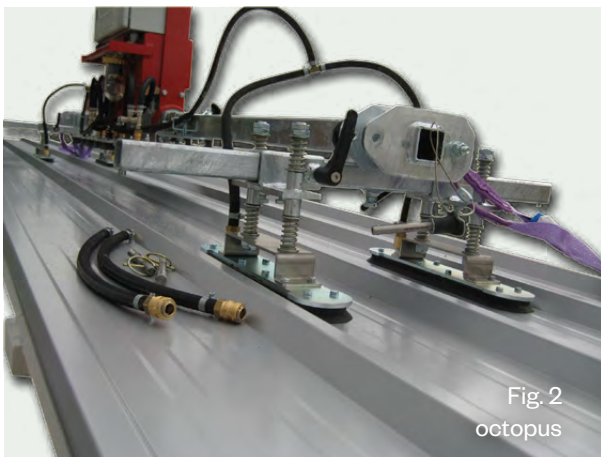

Fig. 2
octopus

ALIGNMENT/MAIN WIND DIRECTION

Before starting to install the panels, square the roof area and use a chalk line to mark control points at the required distances.

Check that the substructure built by the preceding contractor is square and perpendicular; if this is not so, severe problems may ensue during installation, due to shifted panels.

Always lay the panels against the main wind direction. The overlap along the longitudinal joints protects against the penetration of hard, driving rain.

This rule is part of the guidelines for large area and overlapping roof covering materials.



Handling

FIXING ROOF PANELS

When laying the roof panel, it is to be placed at an angle so that the raised bead overlaps properly and the tightness of the longitudinal joint is thus ensured.

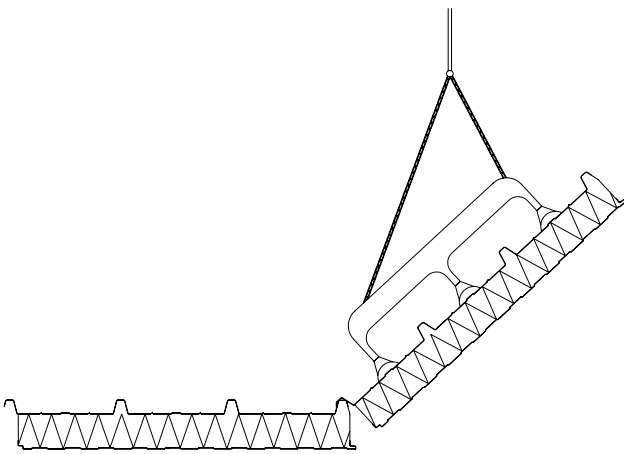

Fasten the panels through the raised bead. Always use the original fastening caps that can be obtained from the panel manufacturer or from a specialist dealer, as these distribute the tightening force of the screw over a larger area such as the sealing washer. A bottom crown attachment is also possible with special screws (see installation guidelines).



spherical cap
PIR+ and fire protection

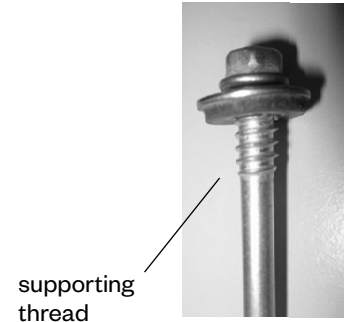

FIXING OF WALL AND FACADE PANELS

Exposed fastening – Support thread screws must always be used for wall panels.

Use screwdrivers with a depth stop to avoid dents when screwing in the screws. Make sure the sealing discs are properly seated to prevent water from penetrating.

For static improvement, use the pressure distribution plate with facade panels.

In the case of horizontal installation, the laying direction is chosen from bottom to top. It should be noted that the element joints are attached in such a way that the elements form a water-repellent drip nose downwards.

For all sealing work, see the information in the installation guidelines.

Just like the roof panels, the wall and facade panels are also distributed either by hand or using a crane. To avoid damaging the coating, the elements must be carefully lifted from the stack.

To prevent the elements from bending, they must be carried upright.

Details

The detail drawings shown here are suggestions for information only. Their correctness and suitability must be checked, based on the particular application.

SEALING THE JOINTS

Sealing of the individual terminal butt joints at the ends, i.e. at the connecting edges to the wall, facade and roof requires special attention, since they all demand special sealing.

All composite construction sealing requires using specially suited sealing tapes, readily available from specialised dealers (acc. to installation guidelines).

BUTT JOINT CONSTRUCTION

THE CROSS JOINT MUST ONLY BE PERFORMED ABOVE A PURLINE (see detailed drawing below or installation guidelines at: brucha.com).

ROOF PITCH: Roofs with transverse joints and roof openings at least 5° (8.6 %).

Example

DETAIL BUTT JOINT CONSTRUCTION

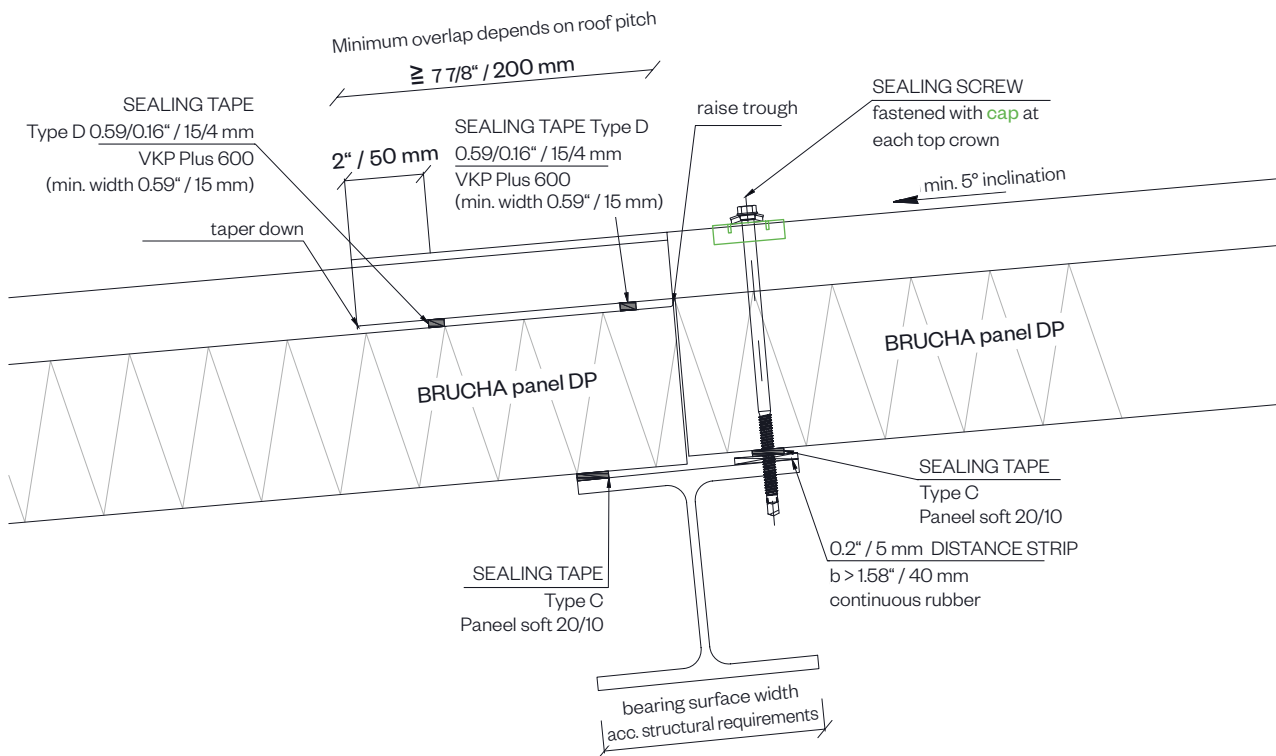

For the sealing material overview chart see installation guidelines.



Details

RIDGE CONSTRUCTION

The proper ridge construction is shown in the detail drawing below. Always raise (tip up) the low profiles of the outer cover of the panel at the edge; use profile fillers and toothed plates. Without toothed plates the profile filler may be removed in a storm or by birds. Furthermore, the plate protects the profile filler from UV light.

The joints of the ridge sheets are designed as a batten seam (see sheet metal working methods). Should sealing be required with elastic sealing compounds, the sealing material must be applied such that it is protected against direct UV radiation.

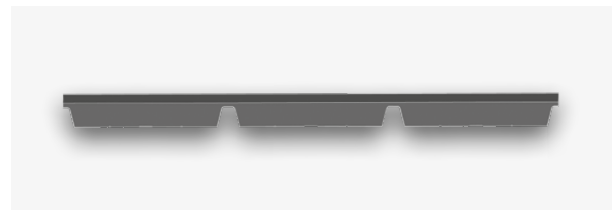

CROWN FILLING TAPE
roof PIR+ and fire protection DP/DP-F – Type Z14

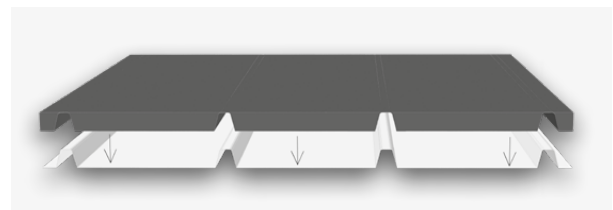

TOOTHED SHEET for DP/DP-F ridge – Type Z13

Example RIDGE CONSTRUCTION

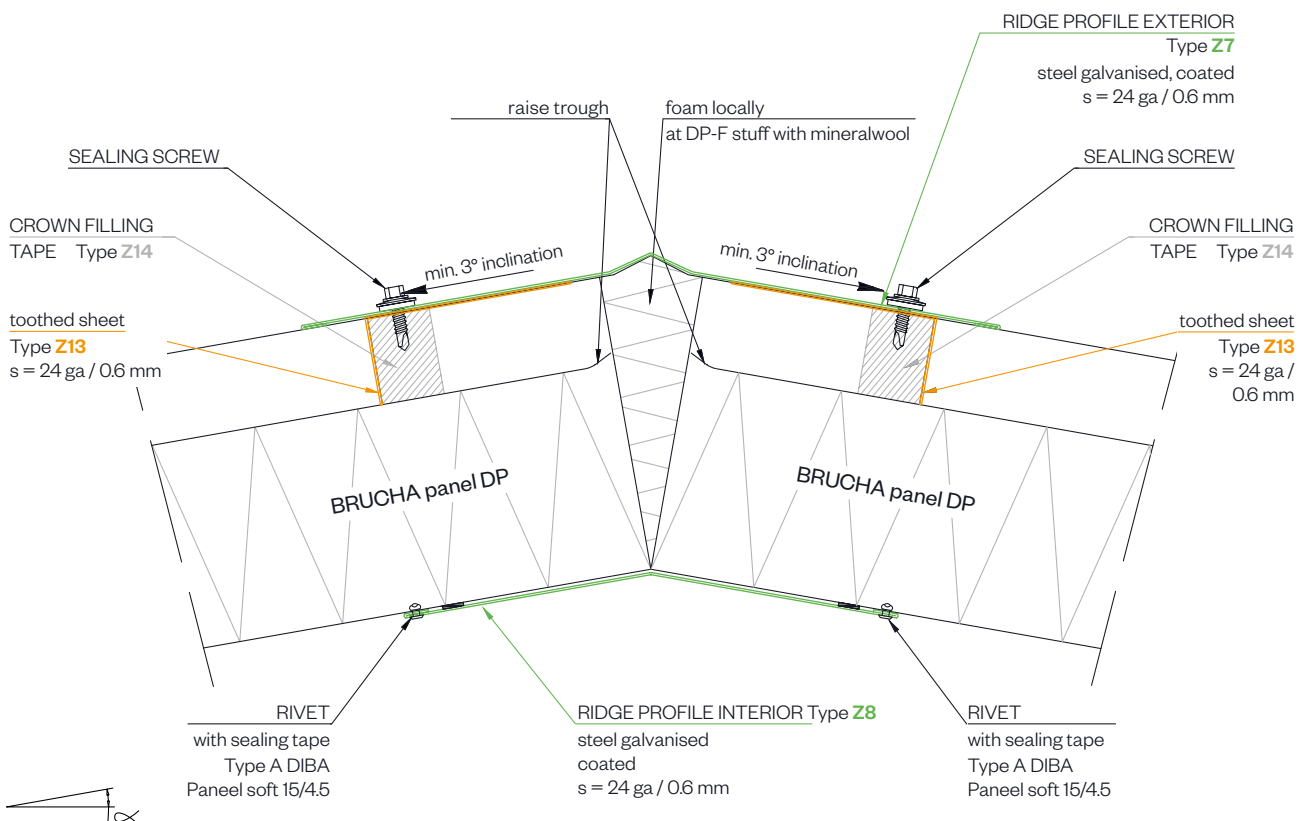

Specify the roof pitch when placing the order, min. 3°.



Details

EAVE CONSTRUCTION

Corresponding to the various kinds of eave construction the elements have to be sealed against the interior space.

Different variants of rainwater gutters can be chosen, in any case you have to organise a professional installation (see our installation guidelines).

NOTE:

For BRUCHA panel fire protection roof DP-F a notch has to be carried out in the eave construction area (available at surcharge).

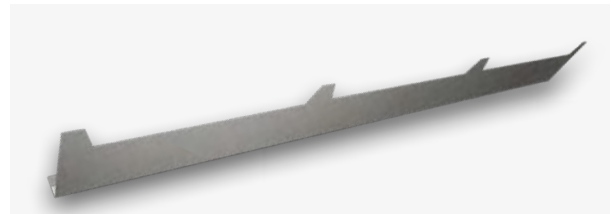

toothed sheet perforated for DP/DP-F eave – Type **Z13b**

Example

EAVE CONSTRUCTION

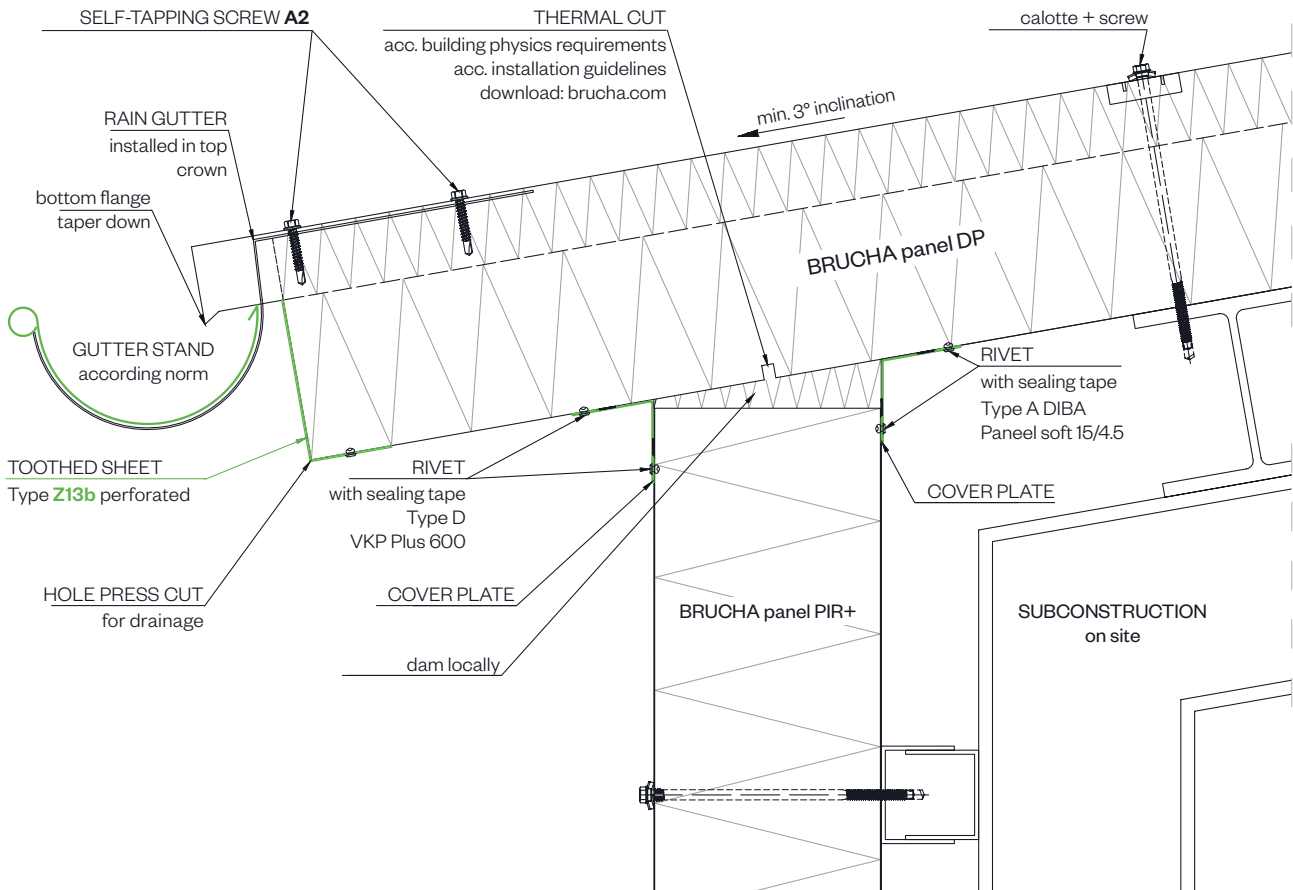

Dimensioning of the gutter according to standard & rainwater accumulation.



Details

Various variants of verge implementation can be chosen, in any case a professional installation has to be guaranteed.

VERGE CONSTRUCTION

As already known from the ridge and eaves construction, an inner sheet must also be provided in the verge in order to achieve a perfect seal.

After laying or screwing the inner sheet metal, the joints between the elements must be stuffed with mineral wool or filled with PU assembly foam.

Normally the outermost cleat is placed on top of the roof panel over the last rib and fixed to the facade directly on both sides.

Depending on the design standard, the longitudinal overlaps of the molded parts are sealed and fitted with butt plates.

Furthermore, the material expansion depending on the type and length of the material must be taken into account.

If necessary, a thermal cut should also be made here, but note the reduction in load-bearing capacity of the overhanging panel part.

Please refer to the OIB [Austrian Building Technology Institute] guidelines.

Example VERGE CONSTRUCTION

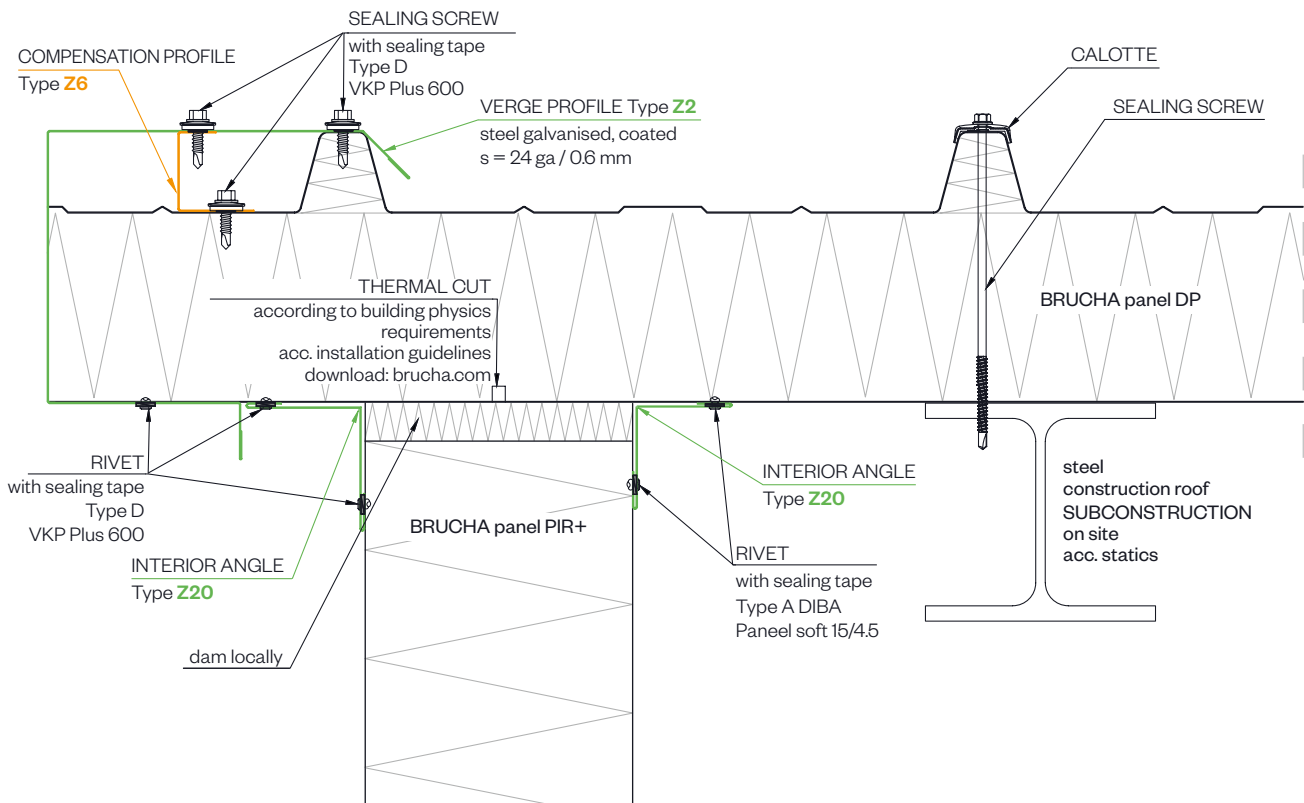

Details

PLINTH CONSTRUCTION

Many different connection types are available between plinth and composite panels (see detail drawings below).

They depend on the type of installation (horizontal or vertical) and on the construction type, of course.

When designing the detail, ensure that penetrating rain water can run off again freely.

Especially in the case of panels with mineral wool core, the insulation may not come into contact with water! Further details can be found in our installation guidelines!

The required plinth profiles are shown in our flashings/ accessories catalogue.

<https://www.brucha.com/downloads>

Example PLINTH CONSTRUCTION vertical installation

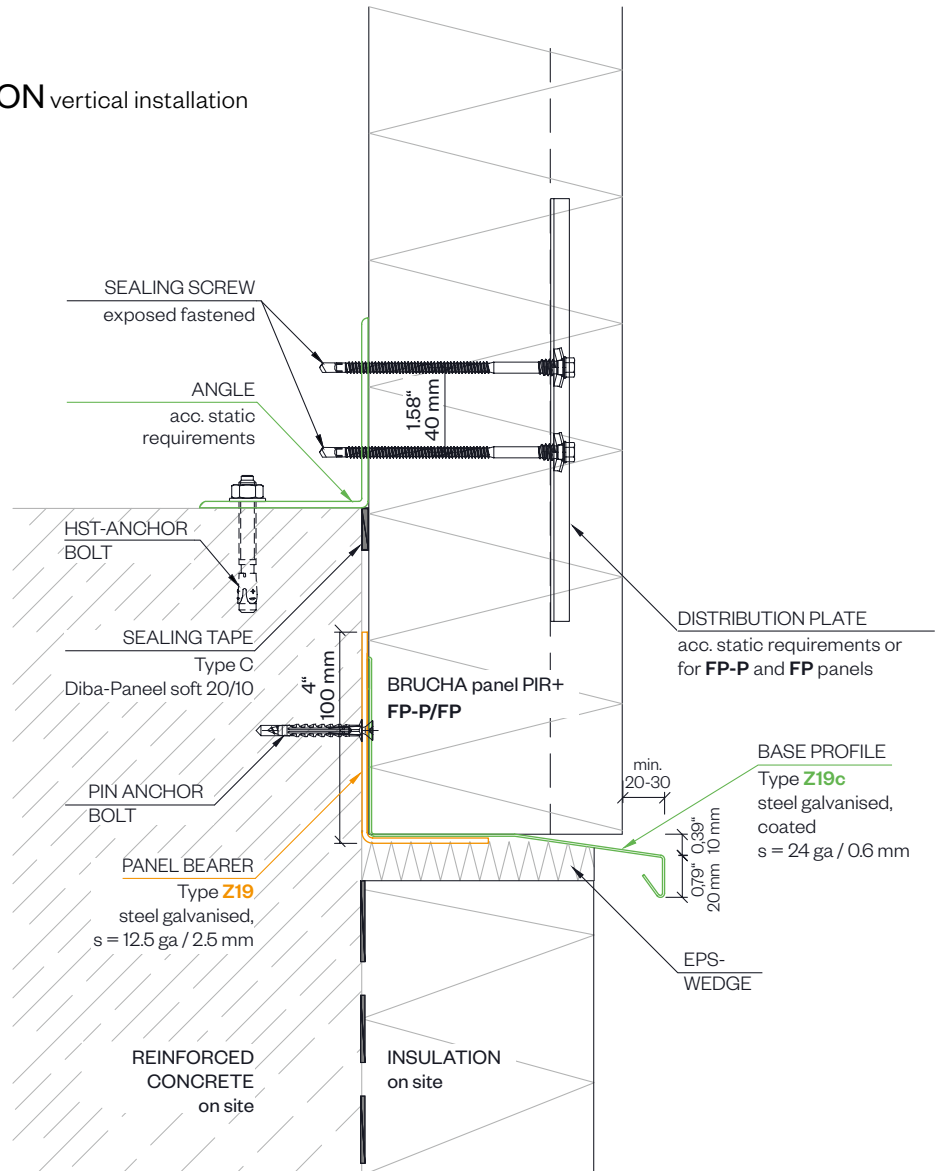



Details

Example PLINTH CONSTRUCTION horizontal installation

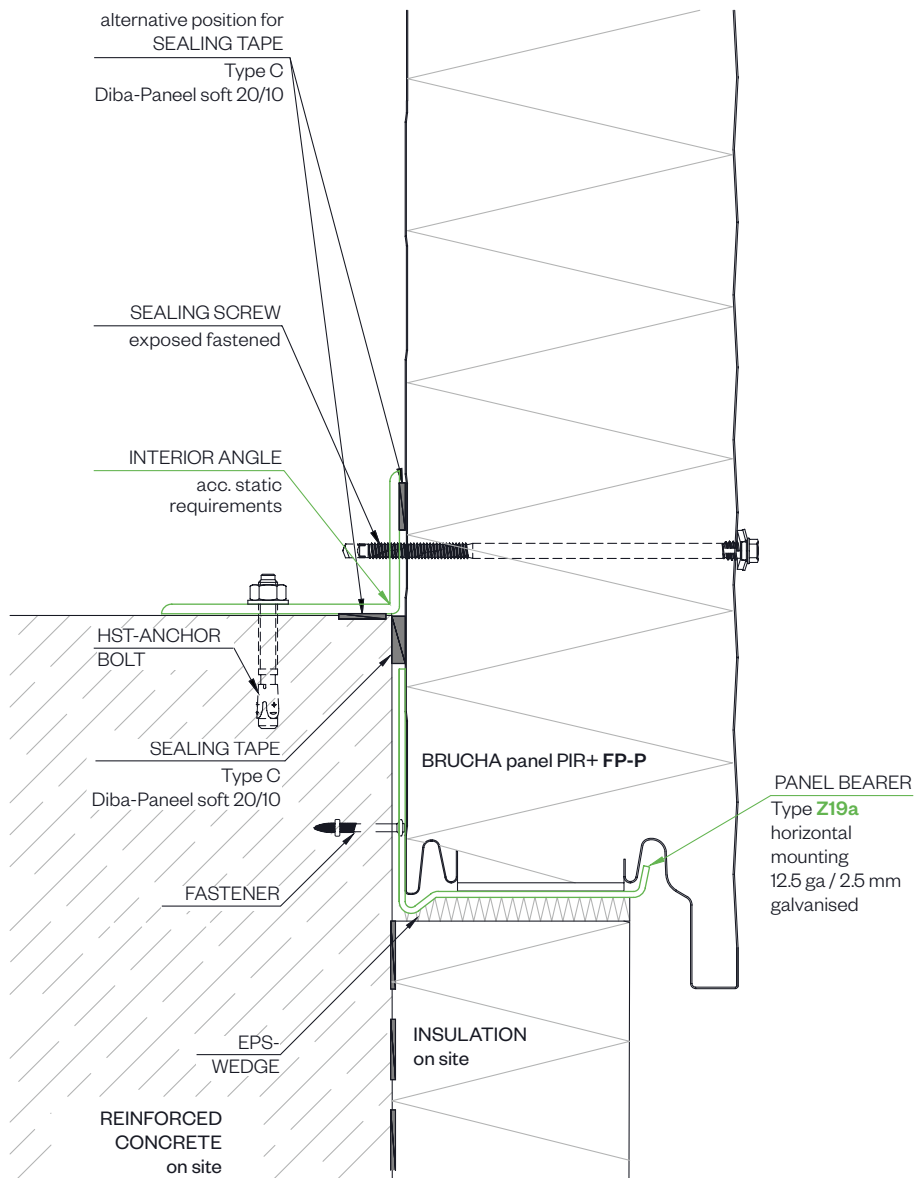

BRUCHA®

PANELS
THAT
CONNECT.



PRODUCTS

- > BRUCHA panels
- > Cold walk-ins
- > Doors
- > EPS insulation boards
- > Accessories

SERVICES

- > Assemblies for special and cold room construction
- > Maintenance and service
- > BRUCHA Food Engineering

BRUCHA Corp. Headoffice
4949 S Syracuse Street, Suite 550
CO 80237 Denver
T +1 (866) BRUCHA1
E infousa@bruchacom

us_02/2023 - All information is considered to be subject to errors in composition or printing errors.

bruchacom